

DODGE COUNTY RIGHT OF WAY PLAT NO. 18

COUNTY STATE AID HIGHWAY NO. 15

S.A.P. NO. 20-615-15

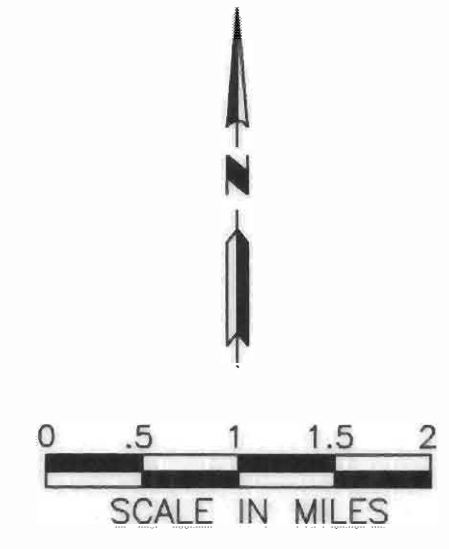

BASIS OF THE BEARING SYSTEM:
Dodge County N.A.D. 1983, base on HARN adjustment.

COUNTY STATE AID HIGHWAY NO. 15

Between Highway No. 30 and C.S.A.H. No. 6

From THE SE COR. SEC. 14-105-16 To THE NE COR. OF SEC. 35-106-16

GROSS LENGTH	21090.63	FEET,	3.994	MILES
BRIDGES LENGTH	0.00	FEET,	0.00	MILES
EXCEPTIONS LENGTH	0.00	FEET,	0.00	MILES
NET LENGTH	21090.63	FEET,	3.994	MILES

BOARD OF COUNTY COMMISSIONERS CERTIFICATION OF PLAT:
THIS PLAT WAS APPROVED AND ACCEPTED BY THE BOARD OF COUNTY COMMISSIONERS OF THE COUNTY OF DODGE, STATE OF MINNESOTA, AT A REGULAR MEETING HELD

THE 16 DAY OF April, 2001

David P. ...
CHAIRPERSON

THE DODGE COUNTY BOARD OF COMMISSIONERS IS HEREBY DESIGNATING THE DEFINITE LOCATION OF COUNTY HIGHWAY NO. 15 FROM T.H. NO. 30 TO COUNTY STATE AID HIGHWAY NO. 6, IN SECTIONS 35 & 36, T106N, R16W AND SECTIONS 1, 2, 11, 12, 13, 14, T105N, R16W. THE PORTION OF SAID HIGHWAY AS SHOWN ON THIS PLAT, PREPARED JOINTLY BY THE COUNTY HIGHWAY DEPARTMENT AND THE COUNTY SURVEYOR OF DODGE COUNTY, IS HEREBY CERTIFIED AS THE OFFICIAL PLAT PURSUANT TO MINNESOTA STATUTES CHAPTER 160.085 AND CHAPTER 160.14, SUB 1.

CERTIFIED BY *Ray W. ...* LICENSE NO. 23733
COUNTY ENGINEER

DATE April 10, 2001

I HEREBY CERTIFY THAT THIS PLAT WAS PREPARED BY ME OR UNDER MY DIRECT SUPERVISION AND THAT I AM A DULY REGISTERED LAND SURVEYOR UNDER THE LAWS OF THE STATE OF MINNESOTA.

Robert W. Brand 8952
SURVEYOR'S SIGNATURE DATE MN. REG. NO.

C 13-5

128287

OFFICE OF COUNTY RECORDER DODGE COUNTY, MN
I HEREBY CERTIFY THAT THIS PLAT HAS BEEN FILED IN THIS OFFICE
AT 10:15 O'CLOCK A.M. ON April 10, 2001 IN BOOK B OF Plats, PAGE 72A
DOCUMENT NO. 128287
Sue A. Allerts
COUNTY RECORDER

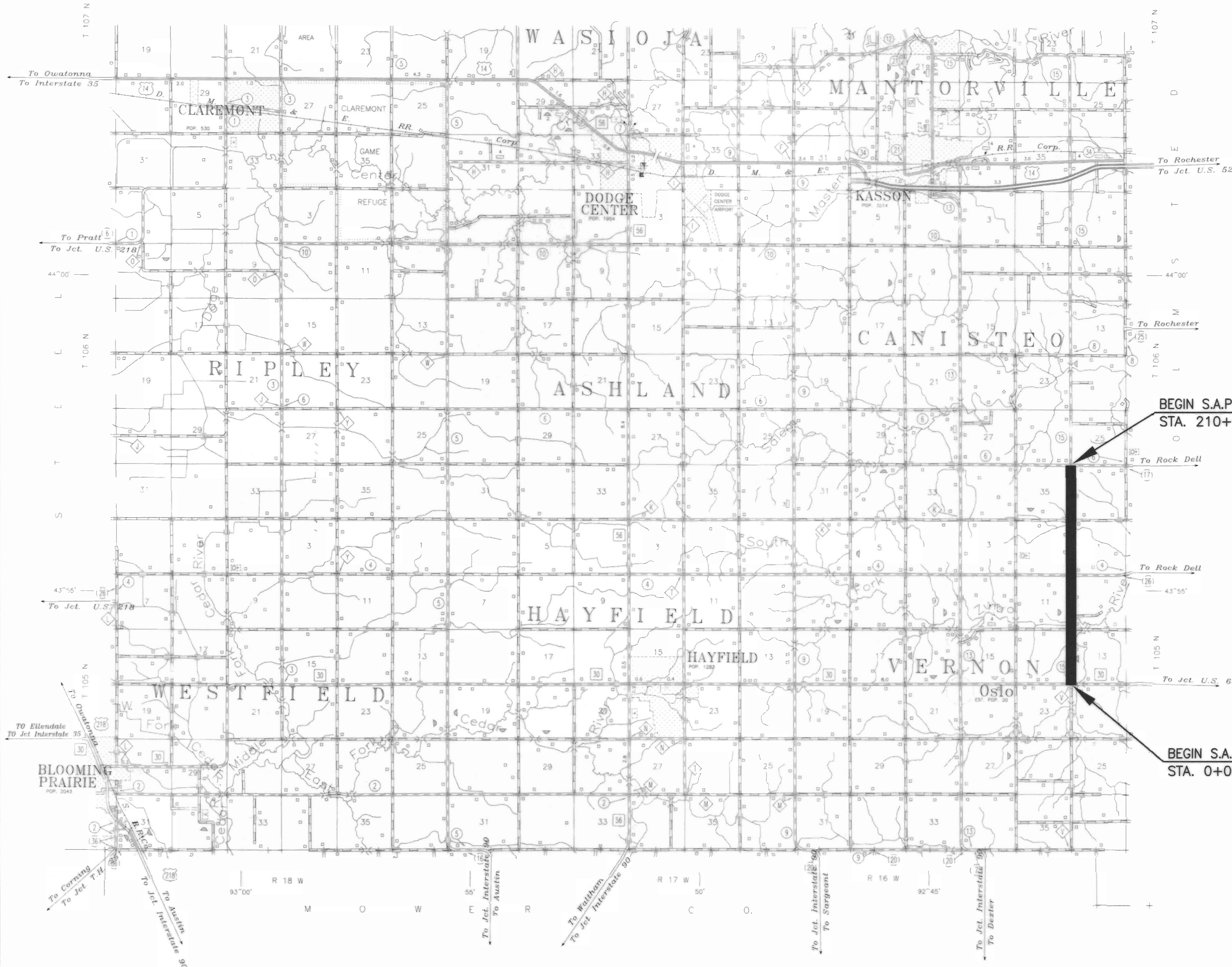

BEGIN S.A.P. 20-615-15
STA. 210+90.63











BEGIN S.A.P. 20-615-15
STA. 0+00.00

DATE REVISION: 03/19/01

DODGE COUNTY RIGHT OF WAY PLAT NO. 18

COUNTY STATE AID HIGHWAY NO. 15

S.A.P. NO. 20-615-15

-  DODGE COUNTY MONUMENT
-  FOUND MONUMENT
-  EXISTING ROAD R/W LINES
-  NEW R/W LINES
-  EXISTING CENTERLINE
-  EXISTING EASEMENT LINE
-  TEMPORARY EASEMENT LINE
-  PROPERTY LINE {PL}
-  SECTION LINE
-  QUARTER LINE



BASIS OF THE BEARING SYSTEM:
Dodge County N.A.D. 1983, base on HARN adjustment.

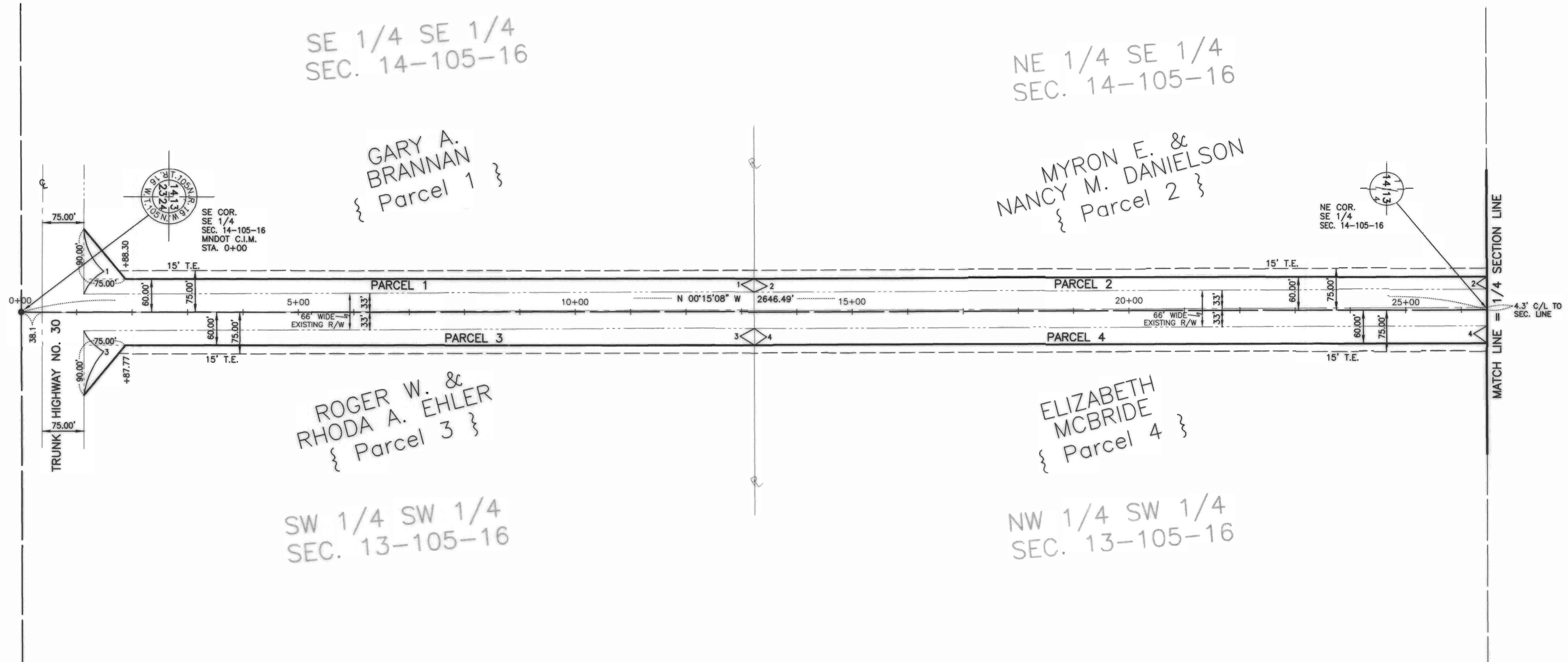

PARCEL NO.	RECORDED OWNER	LOCATION BY 1/4 SECTION	AREA OF NEW R/W (ACRES)	TEMP. EASMT (ACRES)
1	GARY H. BRANNAN	SE 1/4 SE 1/4 SEC. 14-105-16	0.79	0.39
2	MYRON E. & NANCY M. DANIELSON	NE 1/4 SE 1/4 SEC. 14-105-16	0.72	0.46
3	ROGER W. & RHODA A. EHLER	SW 1/4 SW 1/4 SEC. 13-105-16	0.86	0.39
4	ELIZABETH MCBRIDE	NW 1/4 SW 1/4 SEC. 13-105-16	0.92	0.46











C-13-6

02/15/02 DWG DATE: REVISION: 02/09/01

DODGE COUNTY RIGHT OF WAY PLAT NO. 18

COUNTY STATE AID HIGHWAY NO. 15

S.A.P. NO. 20-615-15

-  DODGE COUNTY MONUMENT
-  FOUND MONUMENT
-  EXISTING ROAD R/W LINES
-  NEW R/W LINES
-  EXISTING CENTERLINE
-  EXISTING EASEMENT LINE
-  TEMPORARY EASEMENT LINE
-  PROPERTY LINE {PL}
-  SECTION LINE
-  QUARTER LINE

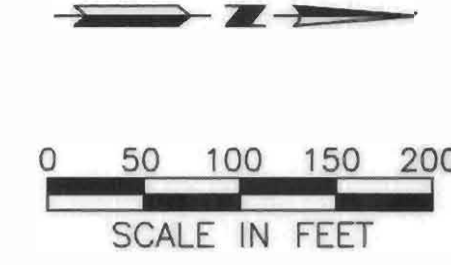

BASIS OF THE BEARING SYSTEM:
Dodge County N.A.D. 1983, base on HARN adjustment.

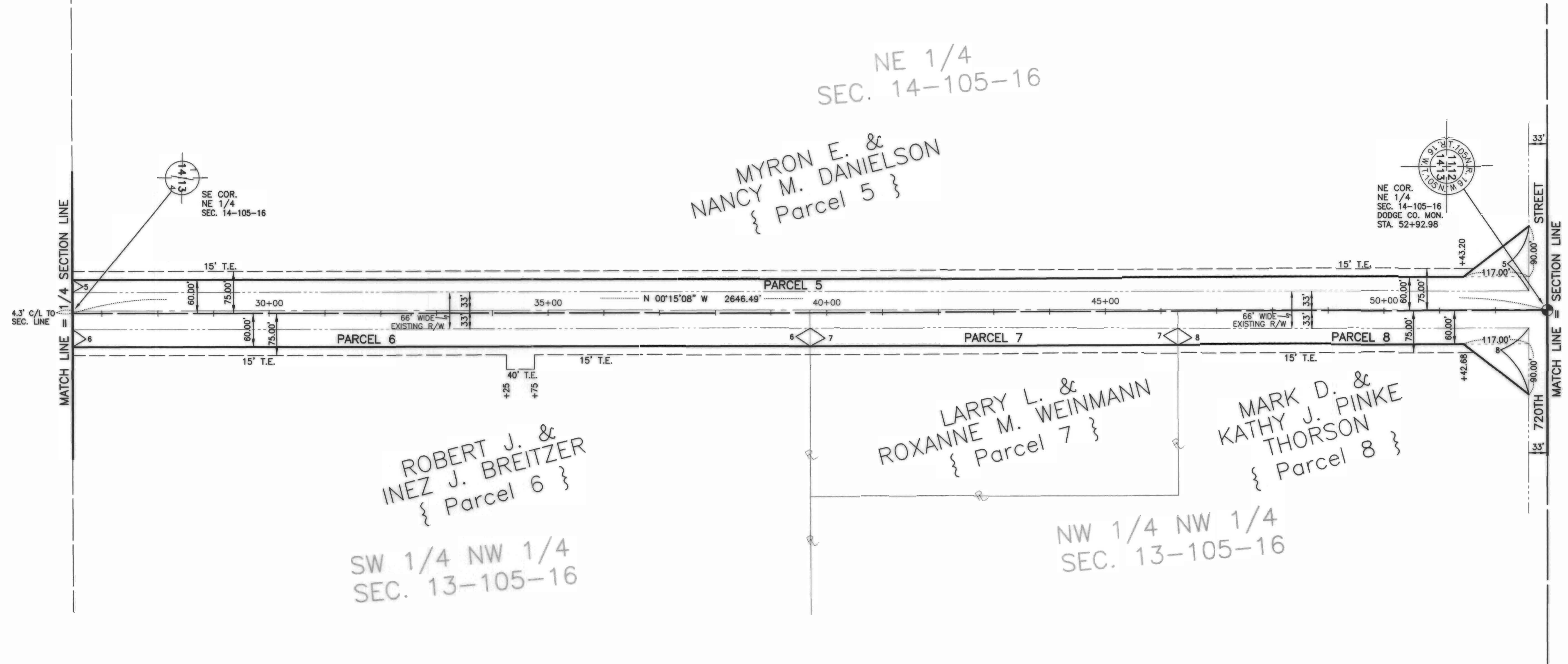

PARCEL NO.	RECORDED OWNER	LOCATION BY 1/4 SECTION	AREA OF NEW R/W (ACRES)	TEMP. EASMT (ACRES)
5	MYRON E. & NANCY M. DANIELSON	NE 1/4 SEC. 14-105-16	1.50	0.86
6	ROBERT J. & INEZ J. BREITZER	SW 1/4 NW 1/4 SEC. 13-105-16	0.97	0.48
7	LARRY L. & ROXANNE M. WEINMANN	NW 1/4 NW 1/4 SEC. 13-105-16	0.47	0.23
8	MARK D. & KATHY J. PINKE THORSON	NW 1/4 NW 1/4 SEC. 13-105-16	0.54	0.18

C 13-7

02/15/03 DWG DATE REVISION 01/18/01

DODGE COUNTY RIGHT OF WAY PLAT NO. 18

COUNTY STATE AID HIGHWAY NO. 15
S.A.P. NO. 20-615-15

- DODGE COUNTY MONUMENT
- FOUND MONUMENT
- EXISTING ROAD R/W LINES
- NEW R/W LINES
- EXISTING CENTERLINE
- EXISTING EASEMENT LINE
- TEMPORARY EASEMENT LINE
- PROPERTY LINE {PL}
- SECTION LINE
- QUARTER LINE

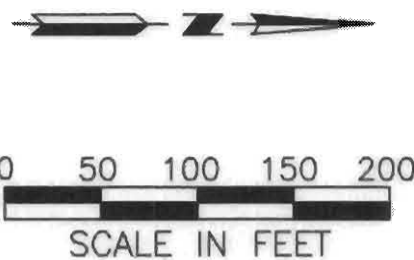

BASIS OF THE BEARING SYSTEM:
Dodge County N.A.D. 1983, base on HARN adjustment.

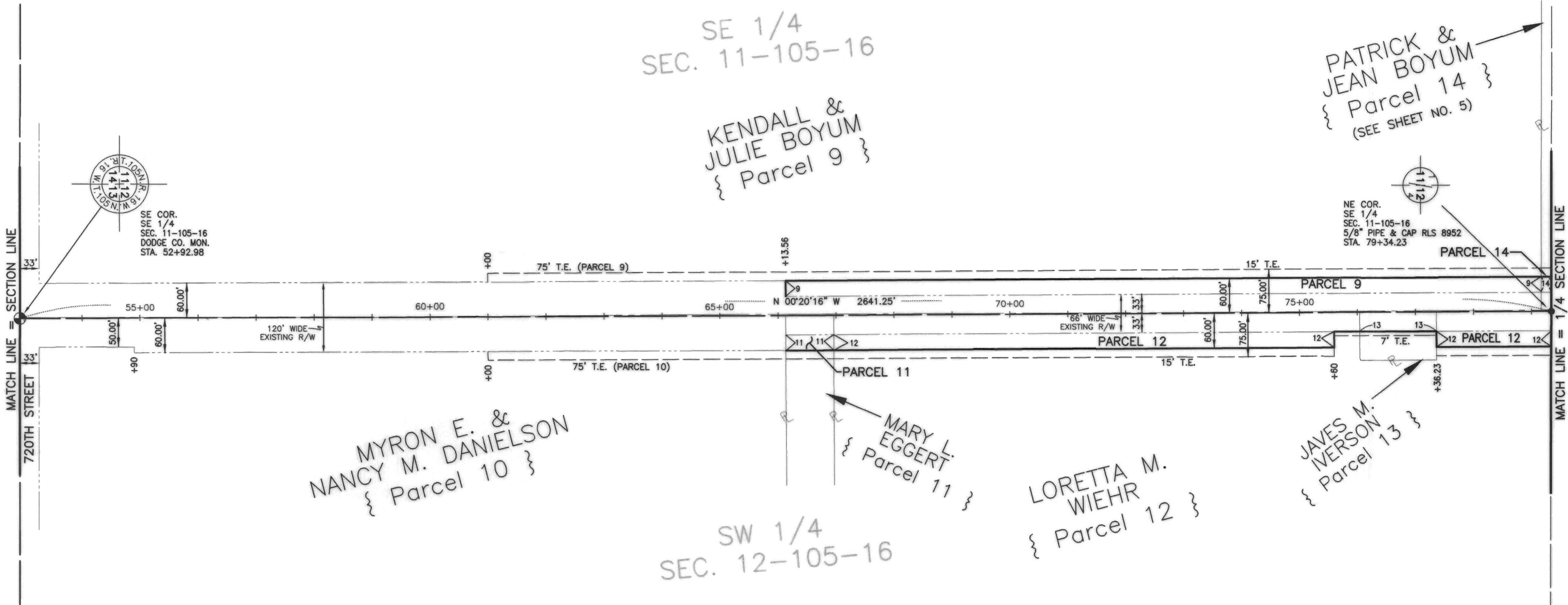

PARCEL NO.	RECORDED OWNER	LOCATION BY 1/4 SECTION	AREA OF NEW R/W (ACRES)	TEMP. EASMT (ACRES)
9	KENDALL & JULIE BOYUM	SE 1/4 SEC. 11-105-16	0.81	0.63
10	MYRON E. & NANCY M. DANIELSON	SW 1/4 SW 1/4 SEC. 12-105-16	0.00	0.18
11	MARY L. EGGERT	NW 1/4 SW 1/4 SEC. 12-105-16	0.05	0.03
12	LORETTA M. WIEHR	NW 1/4 SW 1/4 SEC. 12-105-16	0.66	0.37
13	JAVES M. IVERSON	NW 1/4 SW 1/4 SEC. 12-105-16	0.00	0.02
14	PATRICK & JEAN BOYUM	NE 1/4 SE 1/4 SEC. 12-105-16	SEE SHEET NO. 5	SEE SHEET NO. 5









C 13-8

DATE REVISED: 03/19/01

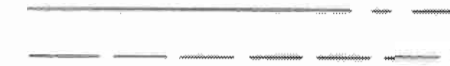
DODGE COUNTY RIGHT OF WAY PLAT NO. 18

COUNTY STATE AID HIGHWAY NO. 15

S.A.P. NO. 20-615-15

-  DODGE COUNTY MONUMENT
-  FOUND MONUMENT
-  EXISTING ROAD R/W LINES
-  NEW R/W LINES
-  EXISTING CENTERLINE
-  EXISTING EASEMENT LINE
-  TEMPORARY EASEMENT LINE
-  PROPERTY LINE {PL}
-  SECTION LINE
-  QUARTER LINE

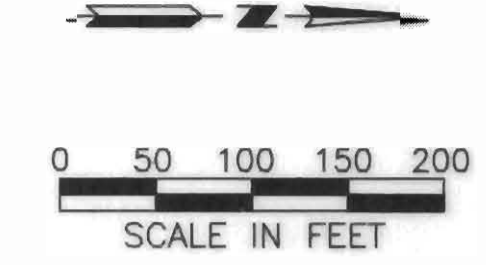

BASIS OF THE BEARING SYSTEM:
Dodge County N.A.D. 1983, base on HARN adjustment.

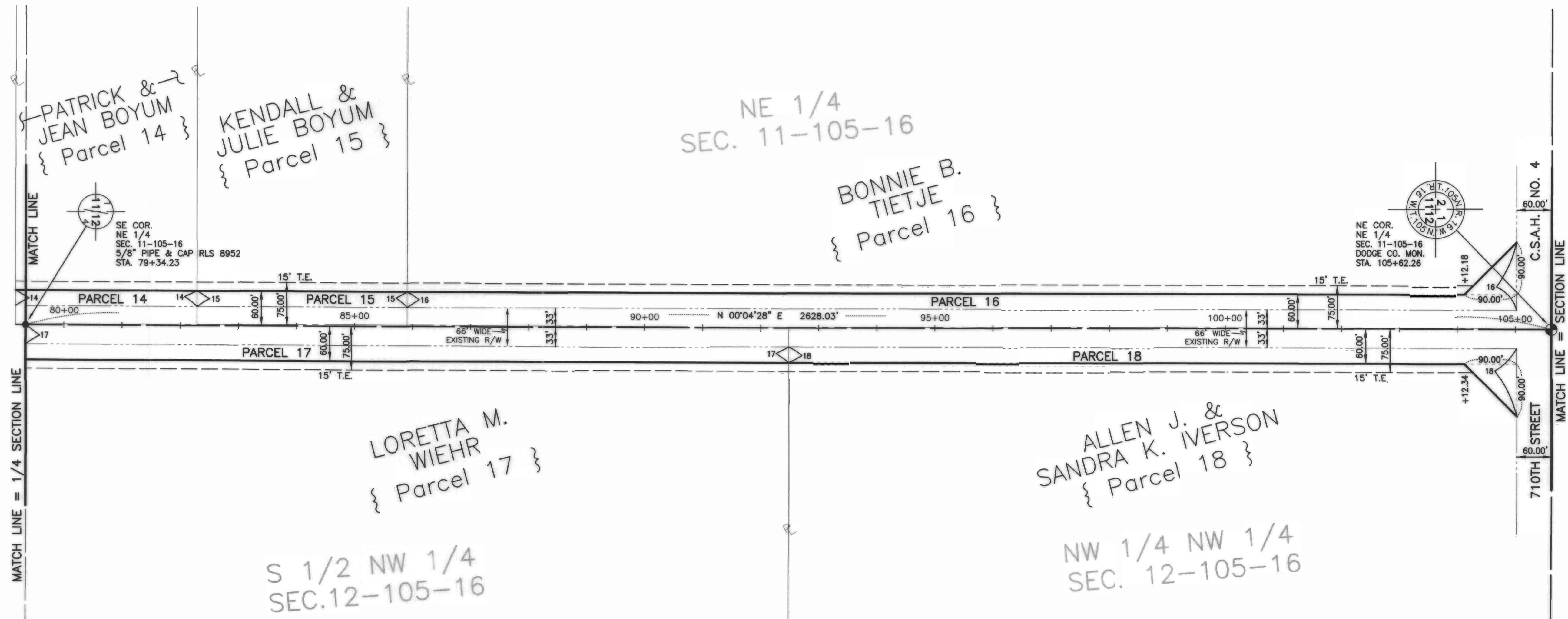

PARCEL NO.	RECORDED OWNER	LOCATION BY 1/4 SECTION	AREA OF NEW R/W (ACRES)	TEMP. EASMT (ACRES)
14	PATRICK & JEAN BOYUM	SE 1/4 NE 1/4 SEC. 11-105-16 & NE 1/4 SE 1/4 SEC. 11-105-16	0.19	0.11
15	KENDALL & JULIE BOYUM	SE 1/4 NE 1/4 SEC. 11-105-16	0.22	0.12
16	BONNIE B. TIETJE	NE 1/4 SEC. 11-105-16	1.28	0.63
17	LORETTA M. WIEHR	SW 1/4 NW 1/4 SEC. 12-105-16	0.81	0.45
18	ALLEN J. & SANDRA K. IVERSON	NW 1/4 NW 1/4 SEC. 12-105-16	0.87	0.40











C 13-9

DATE REVISED: 03/16/01

DODGE COUNTY RIGHT OF WAY PLAT NO. 18

COUNTY STATE AID HIGHWAY NO. 15

S.A.P. NO. 20-615-15

-  DODGE COUNTY MONUMENT
-  FOUND MONUMENT
-  EXISTING ROAD R/W LINES
-  NEW R/W LINES
-  EXISTING CENTERLINE
-  EXISTING EASEMENT LINE
-  TEMPORARY EASEMENT LINE
-  PROPERTY LINE {PL}
-  SECTION LINE
-  QUARTER LINE

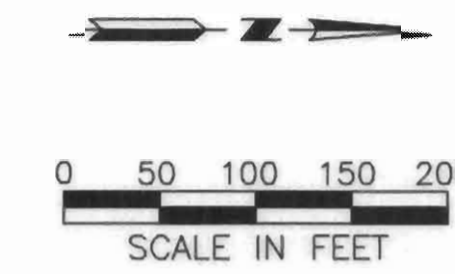

BASIS OF THE BEARING SYSTEM:
Dodge County N.A.D. 1983, base on HARN adjustment.

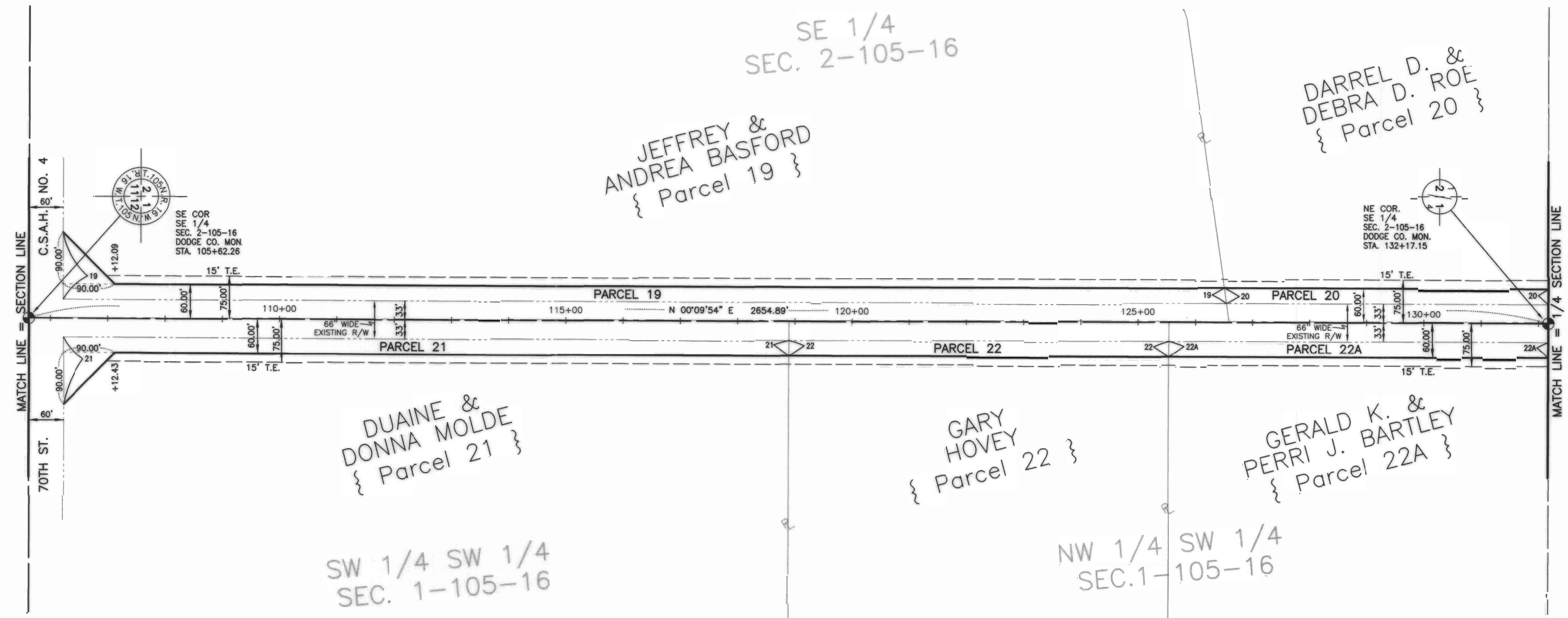

PARCEL NO.	RECORDED OWNER	LOCATION BY 1/4 SECTION	AREA OF NEW R/W (ACRES)	TEMP. EASMT (ACRES)
19	JEFFRY & ANDREA BASFORD	SE 1/4 SEC. 2-105-16	1.35	0.67
20	DARREL D. & DEBRA D. ROE	NE 1/4 SE 1/4 SEC. 2-105-16	0.35	0.20
21	DUAINE MOLDE	SW 1/4 SW 1/4 SEC. 1-105-16	0.88	0.41
22	GARY HOVEY	NW 1/4 SW 1/4 SEC. 1-105-16	0.41	0.23
22A	GERALD K. & PERRI J. BARTLEY	NW 1/4 SW 1/4 SEC. 1-105-16	0.41	0.23











C13-10

DATE REVISIONS: 03/19/01

DODGE COUNTY RIGHT OF WAY PLAT NO. 18

COUNTY STATE AID HIGHWAY NO. 15

S.A.P. NO. 20-615-15

-  DODGE COUNTY MONUMENT
-  FOUND MONUMENT
-  EXISTING ROAD R/W LINES
-  NEW R/W LINES
-  EXISTING CENTERLINE
-  EXISTING EASEMENT LINE
-  TEMPORARY EASEMENT LINE
-  PROPERTY LINE {PL}
-  SECTION LINE
-  QUARTER LINE

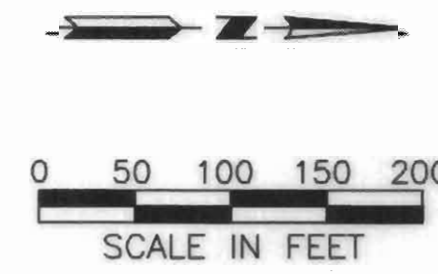

BASIS OF THE BEARING SYSTEM:
Dodge County N.A.D. 1983, base on HARN adjustment.

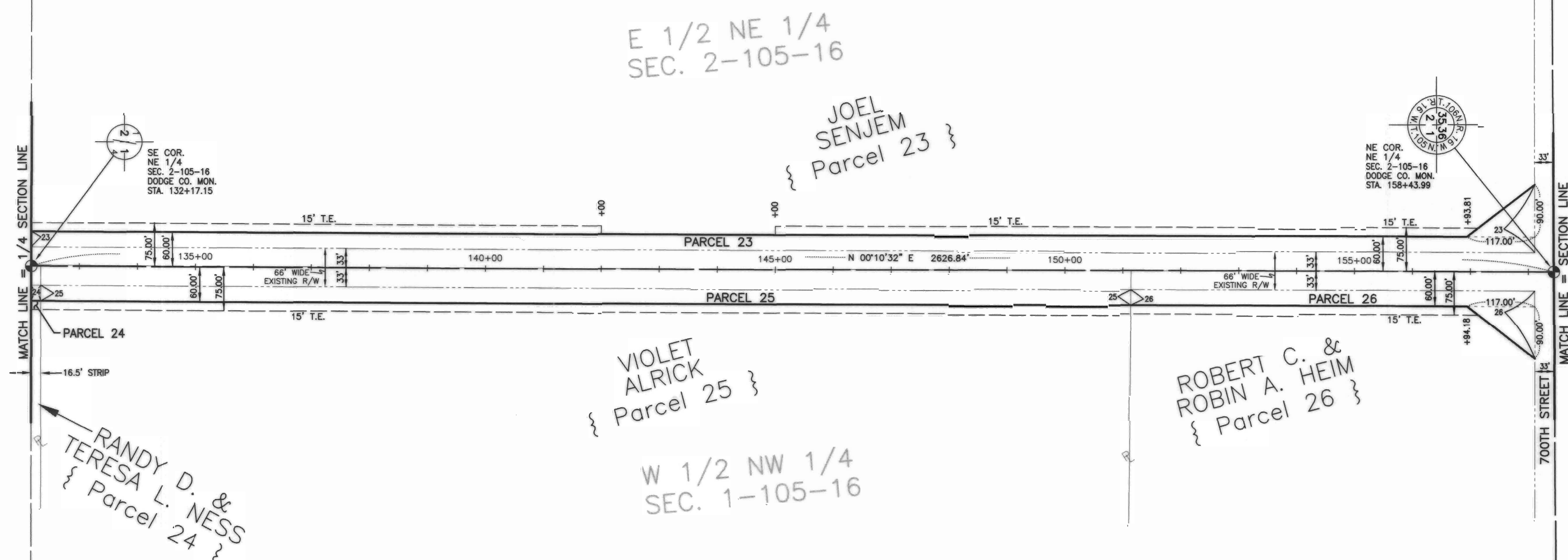

PARCEL NO.	RECORDED OWNER	LOCATION BY 1/4 SECTION	AREA OF NEW R/W (ACRES)	TEMP. EASMT (ACRES)
23	JOEL SENJEM	NE 1/4 SEC. 2-105-16	1.70	0.76
24	RANDY D. & TERESA L. NESS	SW 1/4 NW 1/4 SEC. 1-105-16	0.01	0.01
25	VIOLET ALRICK	NW 1/4 SEC. 1-105-16	1.17	0.65
26	ROBERT C. & ROBIN A. HEIM	NW 1/4 NW 1/4 SEC. 1-105-16	0.55	0.20

C 13-11

DATE REVISED: 03/19/01

AMENDED SHEET 7 of 9 of DODGE COUNTY RIGHT OF WAY PLAT NO. 18

COUNTY STATE AID HIGHWAY NO. 15

S.A.P. NO. 20-615-15

- DODGE COUNTY MONUMENT
- FOUND MONUMENT
- EXISTING ROAD R/W LINES
- NEW R/W LINES
- EXISTING CENTERLINE
- EXISTING EASEMENT LINE
- TEMPORARY EASEMENT LINE
- PROPERTY LINE {PL}
- SECTION LINE
- QUARTER LINE

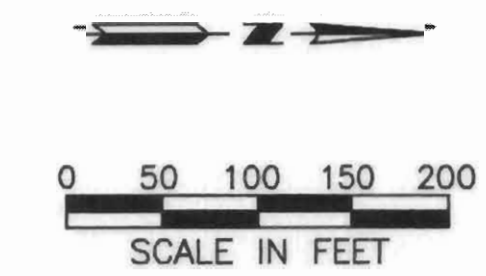

BASIS OF THE BEARING SYSTEM:
Dodge County N.A.D. 1983, base on HARN adjustment.

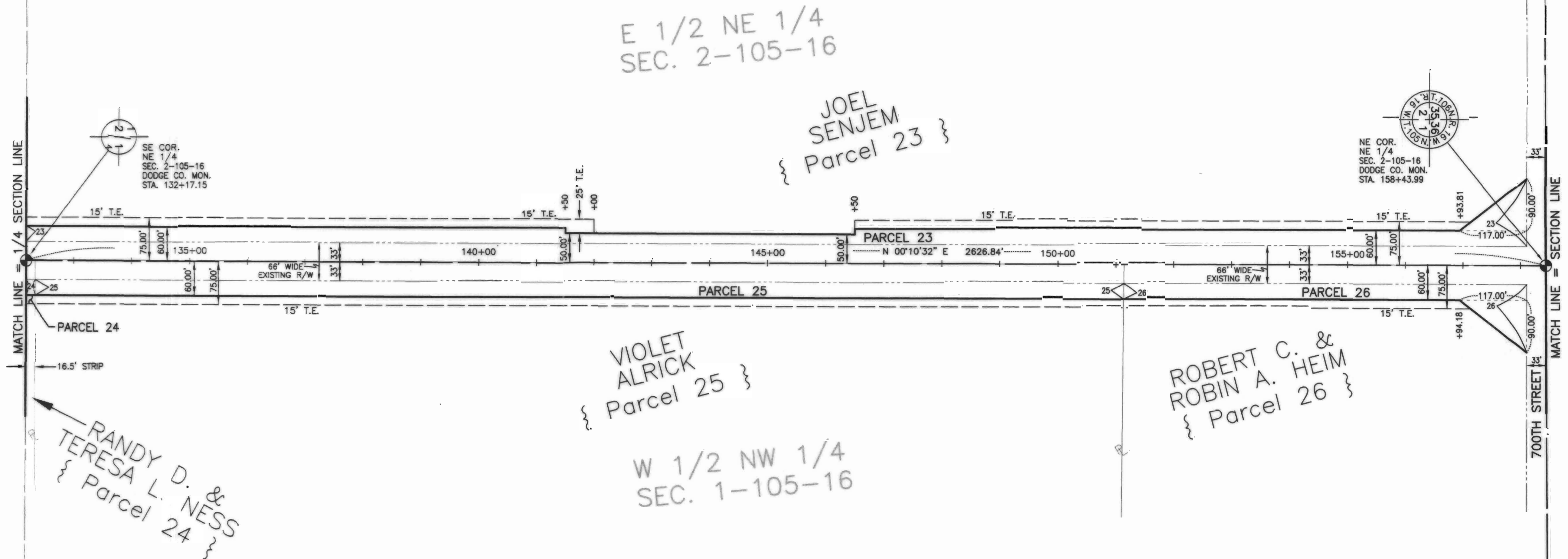

PARCEL NO.	RECORDED OWNER	LOCATION BY 1/4 SECTION	AREA OF NEW R/W (ACRES)	TEMP. EASMT (ACRES)
23	JOEL SENJEM	NE 1/4 SEC. 2-105-16	1.62	0.71
24	RANDY D. & TERESA L. NESS	SW 1/4 NW 1/4 SEC. 1-105-16	0.01	0.01
25	VIOLET ALRICK	NW 1/4 SEC. 1-105-16	1.17	0.65
26	ROBERT C. & ROBIN A. HEIM	NW 1/4 NW 1/4 SEC. 1-105-16	0.55	0.20

BOARD OF COUNTY COMMISSIONERS CERTIFICATION OF PLAT:

THIS PLAT WAS APPROVED AND ACCEPTED BY THE BOARD OF COUNTY COMMISSIONERS OF THE COUNTY OF DODGE, STATE OF MINNESOTA, AT A REGULAR MEETING HELD THE 12 DAY OF June, 2001 A.D.

[Signature]
CHAIRPERSON

I HEREBY CERTIFY THAT THE HIGHWAY LOCATION AND RIGHT OF WAY IS CORRECTLY DESIGNATED ON THIS PLAT

CERTIFIED BY *[Signature]* LICENSE NO. 23733
COUNTY ENGINEER

DATE June 12, 2001

I HEREBY CERTIFY THAT THIS PLAT WAS PREPARED BY ME OR UNDER MY DIRECT SUPERVISION AND THAT I AM A DULY REGISTERED LAND SURVEYOR UNDER THE LAWS OF THE STATE OF MINNESOTA.

[Signature] DATE June 6, 2001 MN. LIC. NO. 8952
SURVEYOR'S SIGNATURE

C13-12











OFFICE OF COUNTY RECORDER DODGE COUNTY, MN
I HEREBY CERTIFY THAT THIS PLAT HAS BEEN FILED IN THIS OFFICE
AT 4:15 O'CLOCK P.M. ON June 12, 2001 IN
BOOK B OF Plats, PAGE 22A-1
DOCUMENT NO. 129413

[Signature]
COUNTY RECORDER

DODGE COUNTY RIGHT OF WAY PLAT NO. 18

COUNTY STATE AID HIGHWAY NO. 15

S.A.P. NO. 20-615-15

-  DODGE COUNTY MONUMENT
-  FOUND MONUMENT
-  EXISTING ROAD R/W LINES
-  NEW R/W LINES
-  EXISTING CENTERLINE
-  EXISTING EASEMENT LINE
-  TEMPORARY EASEMENT LINE
-  PROPERTY LINE {PL}
-  SECTION LINE
-  QUARTER LINE

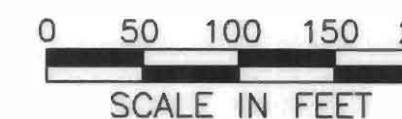

BASIS OF THE BEARING SYSTEM:
Dodge County N.A.D. 1983, base on HARN adjustment.

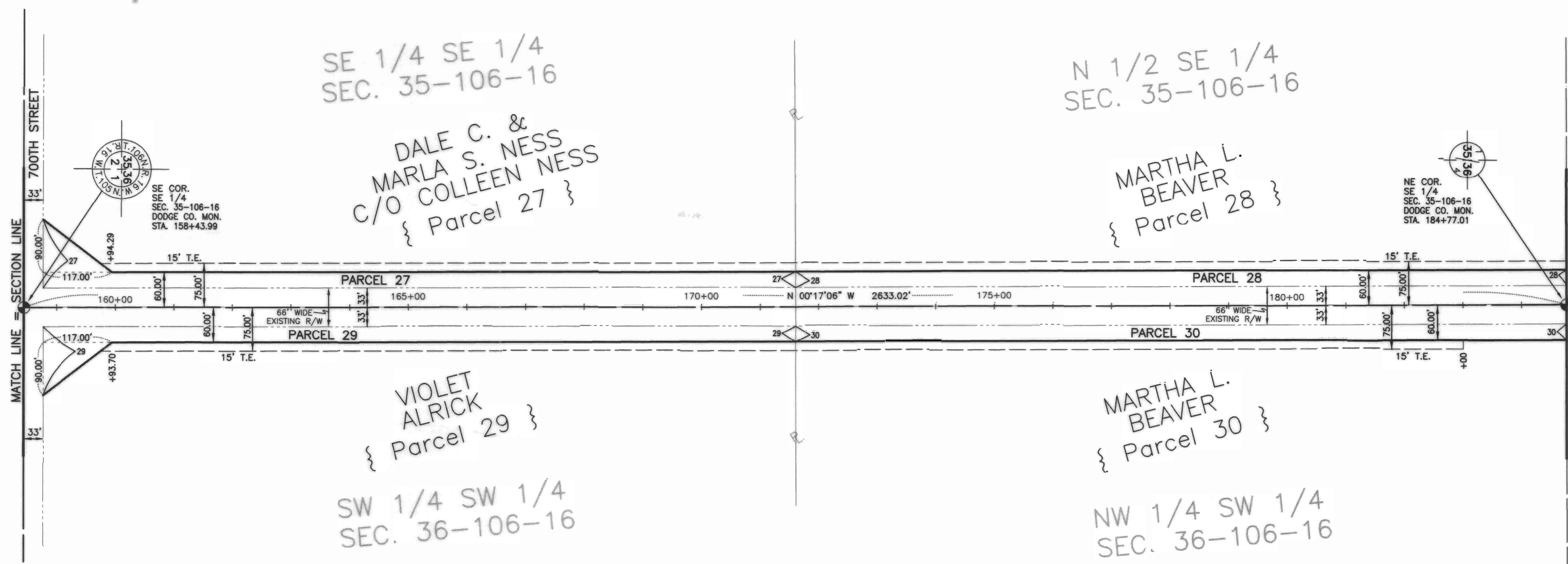

PARCEL NO.	RECORDED OWNER	LOCATION BY 1/4 SECTION	AREA OF NEW R/W (ACRES)	TEMP. EASMT (ACRES)
27	DALE C. & MARLA S. NESS C/O COLLEEN B. NESS	SE 1/4 SE 1/4 SEC. 35-106-16	0.92	0.40
28	MARTHA L. BEAVER	NE 1/4 SE 1/4 SEC. 35-106-16	0.81	0.45
29	VIOLET ALRICK	SW 1/4 SW 1/4 SEC. 36-106-16	0.92	0.40
30	MARTHA L. BEAVER	NW 1/4 SW 1/4 SEC. 36-106-16	0.82	0.39











C 13-13

03/15/2016 DATE REVISION: 03/19/2016

DODGE COUNTY RIGHT OF WAY PLAT NO. 18

COUNTY STATE AID HIGHWAY NO. 15

S.A.P. NO. 20-615-15

-  DODGE COUNTY MONUMENT
-  FOUND MONUMENT
-  EXISTING ROAD R/W LINES
-  NEW R/W LINES
-  EXISTING CENTERLINE
-  EXISTING EASEMENT LINE
-  TEMPORARY EASEMENT LINE
-  PROPERTY LINE {PL}
-  SECTION LINE
-  QUARTER LINE

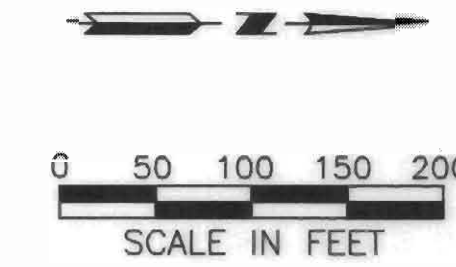

BASIS OF THE BEARING SYSTEM:
Dodge County N.A.D. 1983, base on HARN adjustment.

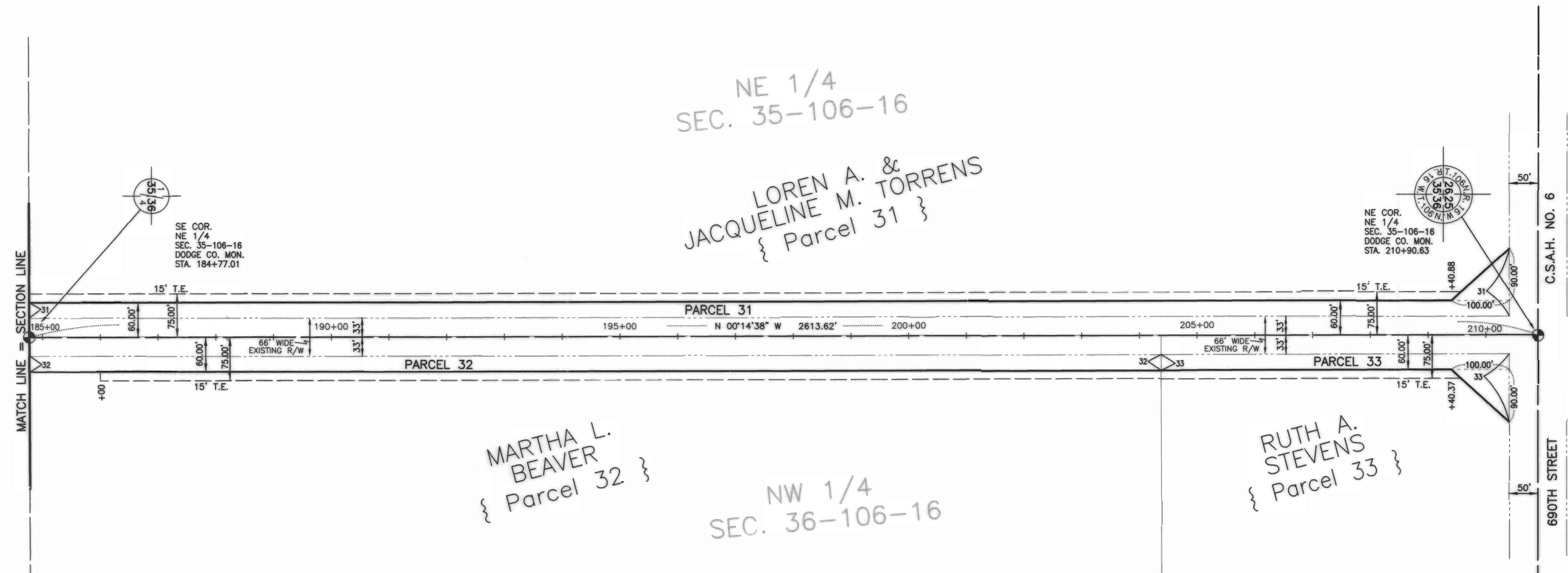

C 13-14

PARCEL NO.	RECORDED OWNER	LOCATION BY 1/4 SECTION	AREA OF NEW R/W (ACRES)	TEMP. EASMT (ACRES)
31	LOREN & JACQUELINE M. TORRENS	NE 1/4 SEC. 35-106-16	1.69	0.85
32	MARTHA L. BEAVER	NW 1/4 SEC. 36-106-16	1.21	0.63
33	RUTH A. STEVENS	NW 1/4 NW 1/4 SEC. 36-106-16	0.48	0.18