

DODGE COUNTY RIGHT OF WAY PLAT NO. 20

COUNTY STATE AID HIGHWAY NO. 16

S.A.P. NO. 20-616-10

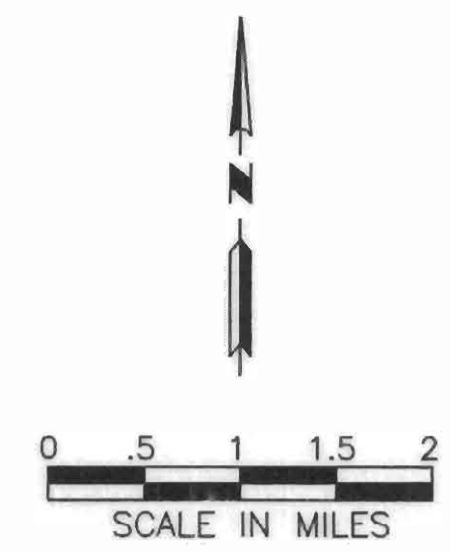

COUNTY STATE AID HIGHWAY NO. 16

Between C.S.A.H. No. 9 and T.H. No. 57

From THE SW COR. SEC. 12-107-17 To 381' WEST OF THE SE COR. OF SEC. 8-107-16

GROSS LENGTH	15,561.46	FEET,	2.947	MILES
BRIDGES LENGTH	0.00	FEET,	0.00	MILES
EXCEPTIONS LENGTH	0.00	FEET,	0.00	MILES
NET LENGTH	15,561.45	FEET,	2.947	MILES

BOARD OF COUNTY COMMISSIONERS CERTIFICATION OF PLAT:
THIS PLAT WAS APPROVED AND ACCEPTED BY THE BOARD OF COUNTY COMMISSIONERS OF THE COUNTY OF DODGE, STATE OF MINNESOTA, AT A REGULAR MEETING HELD

THE 17 DAY OF December, 2002

Don J. Gray
CHAIRPERSON

THE DODGE COUNTY BOARD OF COMMISSIONERS IS HEREBY DESIGNATING THE DEFINITE LOCATION OF COUNTY HIGHWAY NO. 16 FROM COUNTY STATE AID HIGHWAY NO. 9 TO TRUNK HIGHWAY NO. 57, IN SECTIONS 12, 13, T107N, R17W AND SECTIONS 7, 8, 17, 18, T107N, R16W. THE PORTION OF SAID HIGHWAY AS SHOWN ON THIS PLAT, PREPARED JOINTLY BY THE COUNTY HIGHWAY DEPARTMENT AND THE COUNTY SURVEYOR OF DODGE COUNTY, IS HEREBY CERTIFIED AS THE OFFICIAL PLAT PURSUANT TO MINNESOTA STATUTES CHAPTER 160.085 AND CHAPTER 160.14, SUB 1.

CERTIFIED BY *Greg W. Kuhlberg* LICENSE NO. 23733
COUNTY ENGINEER

DATE Dec. 17, 2002

I HEREBY CERTIFY THAT THIS PLAT WAS PREPARED BY ME OR UNDER MY DIRECT SUPERVISION AND THAT I AM A DULY REGISTERED LAND SURVEYOR UNDER THE LAWS OF THE STATE OF MINNESOTA.

Roger W. Brand 8952
SURVEYOR'S SIGNATURE DATE MN. LICENSE NO.

C 13-15

OFFICE OF COUNTY RECORDER DODGE COUNTY, MN
I HEREBY CERTIFY THAT THIS PLAT HAS BEEN FILED IN THIS OFFICE
AT 11:45 O'CLOCK A.M. ON
December 17, 2002 IN
BOOK B OF Plats, PAGE 88A
DOCUMENT NO. 141031
Lucy A. Alhrosta
COUNTY RECORDER

DATE: 12/17/02

DODGE COUNTY RIGHT OF WAY PLAT NO. 20

COUNTY STATE AID HIGHWAY NO. 16

S.A.P. NO. 20-616-10

- DODGE COUNTY MONUMENT
- FOUND MONUMENT
- EXISTING ROAD R/W LINES
- NEW R/W LINES
- EXISTING CENTERLINE
- TEMPORARY EASEMENT LINE
- PROPERTY LINE {PL}
- SECTION LINE
- QUARTER LINE
- SUBDIVISION LOT LINE

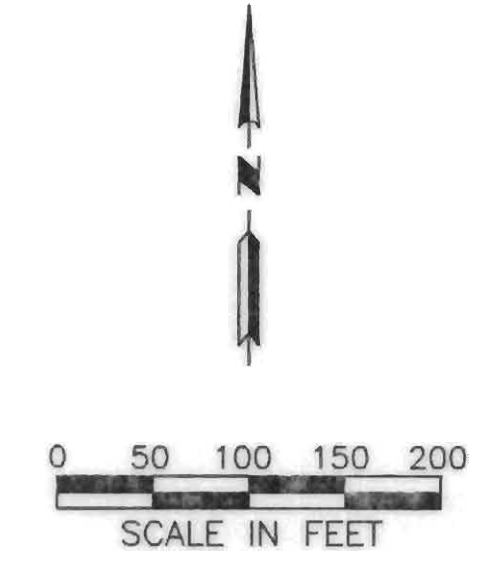

BASIS OF THE BEARING SYSTEM:
Bearings are in relationship with the south line of the SW 1/4 Section 12-107-17.

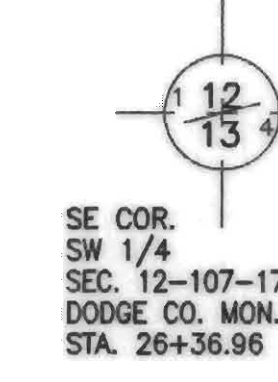
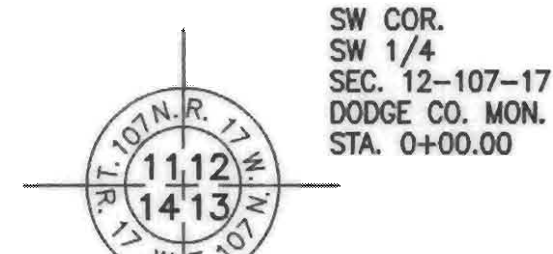
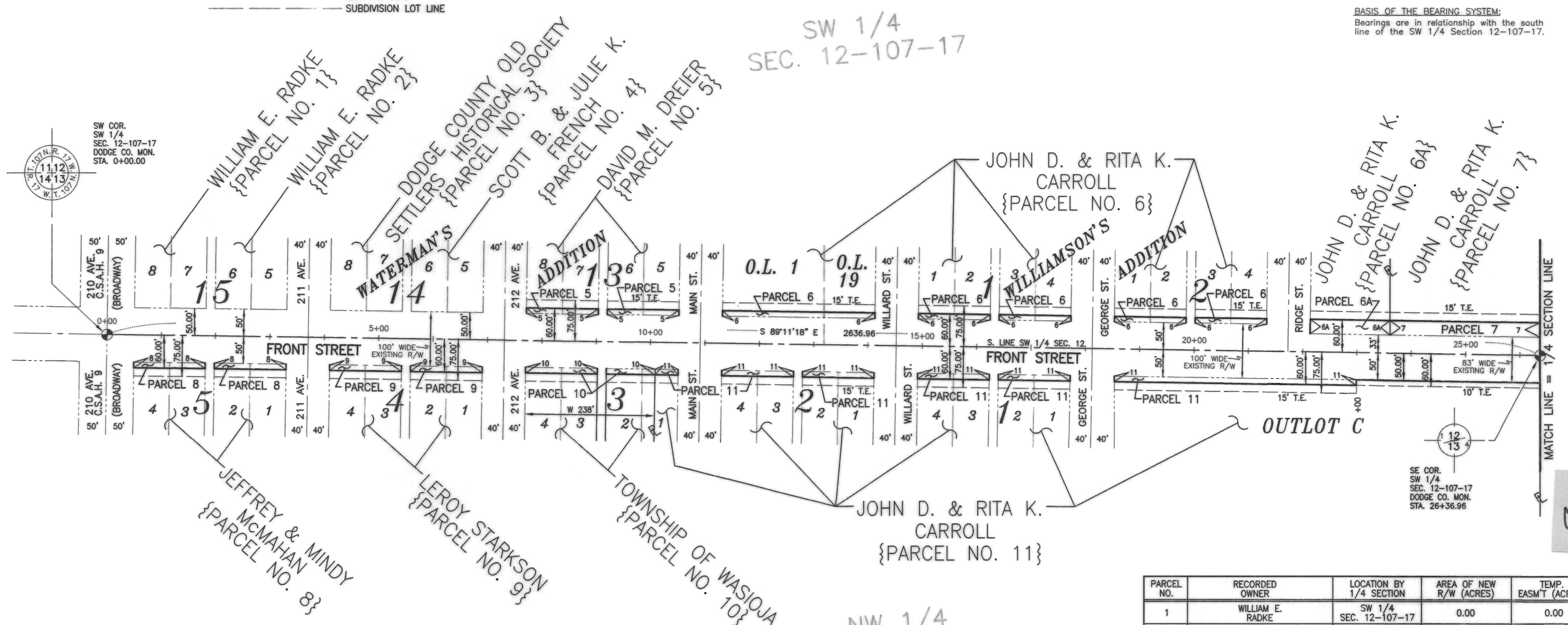

C 13-16

PARCEL NO.	RECORDED OWNER	LOCATION BY 1/4 SECTION	AREA OF NEW R/W (ACRES)	TEMP. EASM'T (ACRES)
1	WILLIAM E. RADKE	SW 1/4 SEC. 12-107-17	0.00	0.00
2	WILLIAM E. RADKE	SW 1/4 SEC. 12-107-17	0.00	0.00
3	DODGE COUNTY OLD SETTLERS HISTORICAL SOCIETY	SW 1/4 SEC. 12-107-17	0.00	0.00
4	SCOTT B. & JULIE K. FRENCH	SW 1/4 SEC. 12-107-17	0.00	0.00
5	DAVID M. DREIER	SW 1/4 SEC. 12-107-17	0.06	0.09
6	JOHN D. & RITA K. CARROLL	SW 1/4 SEC. 12-107-17	0.19	0.28
6A	JOHN D. & RITA K. CARROLL	SW 1/4 SEC. 12-107-17	0.09	0.05
7	JOHN D. & RITA K. CARROLL	SW 1/4 SEC. 12-107-17	SEE SHEET 3	SEE SHEET 3
8	JEFFREY & MINDY McMAHAN	NW 1/4 SEC. 13-107-17	0.06	0.09
9	LEROY STARKSON	NW 1/4 SEC. 13-107-17	0.06	0.09
10	TOWNSHIP OF WASIOJA	NW 1/4 SEC. 13-107-17	0.05	0.08
11	JOHN D. & RITA K. CARROLL	NW 1/4 SEC. 13-107-17	0.23	0.43









NW 1/4 SEC. 13-107-17

DATE: 12/24/22

DODGE COUNTY RIGHT OF WAY PLAT NO. 20

COUNTY STATE AID HIGHWAY NO. 16

S.A.P. NO. 20-616-10

-  DODGE COUNTY MONUMENT
-  FOUND MONUMENT
-  EXISTING ROAD R/W LINES
-  NEW R/W LINES
-  EXISTING CENTERLINE
-  TEMPORARY EASEMENT LINE
-  PROPERTY LINE {PL}
-  SECTION LINE
-  QUARTER LINE

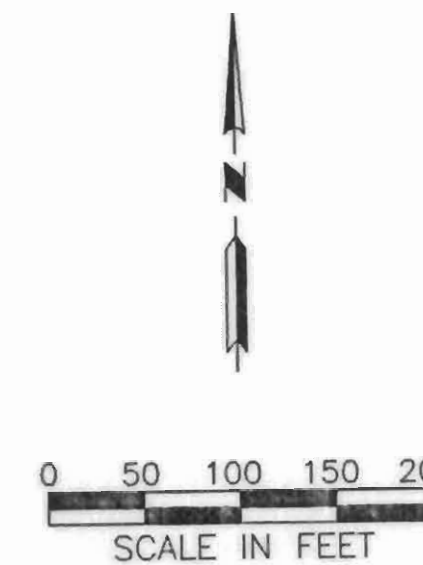

BASIS OF THE BEARING SYSTEM:
Bearings are in relationship with the south line of the SE 1/4 Section 12-107-16.

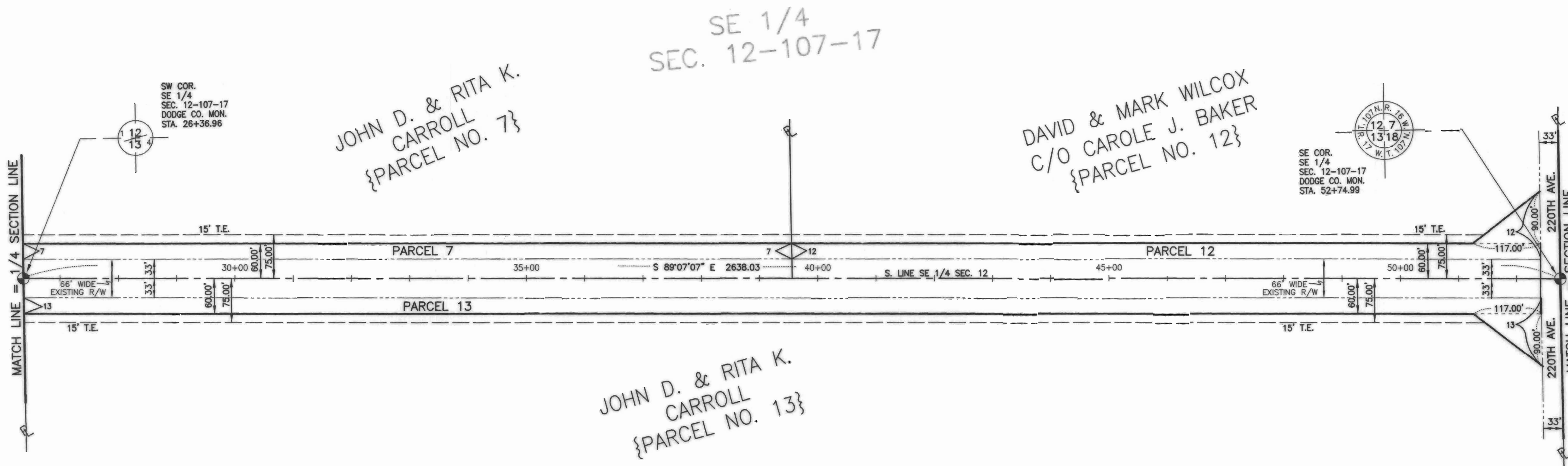









0 13-10

DODGE COUNTY RIGHT OF WAY PLAT NO. 20

COUNTY STATE AID HIGHWAY NO. 16

S.A.P. NO. 20-616-10

-  DODGE COUNTY MONUMENT
-  FOUND MONUMENT
-  EXISTING ROAD R/W LINES
-  NEW R/W LINES
-  EXISTING CENTERLINE
-  TEMPORARY EASEMENT LINE
-  PROPERTY LINE {PL}
-  SECTION LINE
-  QUARTER LINE

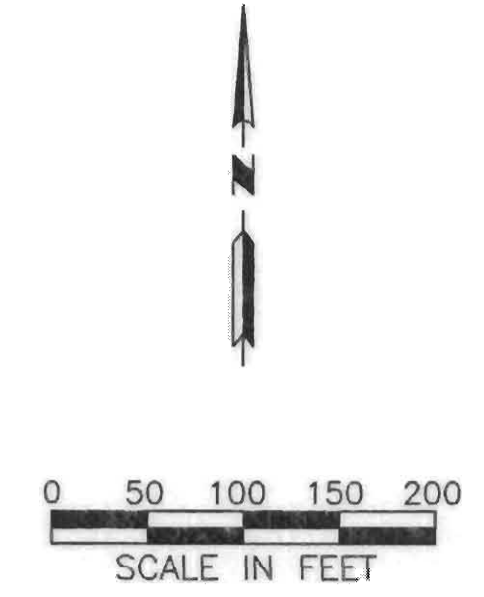

BASIS OF THE BEARING SYSTEM:
Bearings are in relationship with the south line of the SW 1/4 Section 7-107-16.

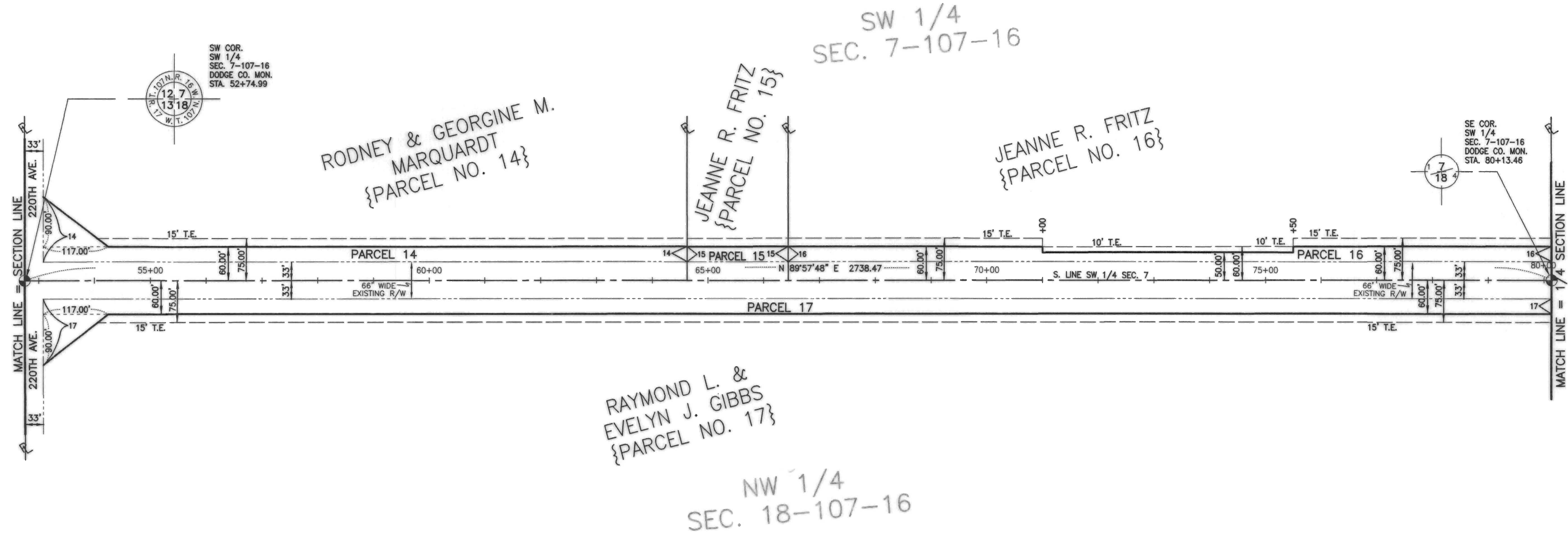

PARCEL NO.	RECORDED OWNER	LOCATION BY 1/4 SECTION	AREA OF NEW R/W (ACRES)	TEMP. EASMT (ACRES)
14	RODNEY & GEORGINE M. MARQUARDT	SW 1/4 SEC. 7-107-16	0.84	0.36
15	JEANNE R. FRITZ	SW 1/4 SEC. 7-107-16	0.11	0.06
16	JEANNE R. FRITZ	SW 1/4 SEC. 7-107-16	0.75	0.42
17	RAYMOND L. & EVELYN J. GIBBS	NW 1/4 SEC. 18-107-16	2.21	1.12









C 13-18

DATE: 11/27/02

DODGE COUNTY RIGHT OF WAY PLAT NO. 20

COUNTY STATE AID HIGHWAY NO. 16

S.A.P. NO. 20-616-10

-  DODGE COUNTY MONUMENT
-  FOUND MONUMENT
-  EXISTING ROAD R/W LINES
-  NEW R/W LINES
-  EXISTING CENTERLINE
-  TEMPORARY EASEMENT LINE
-  PROPERTY LINE {PL}
-  SECTION LINE
-  QUARTER LINE

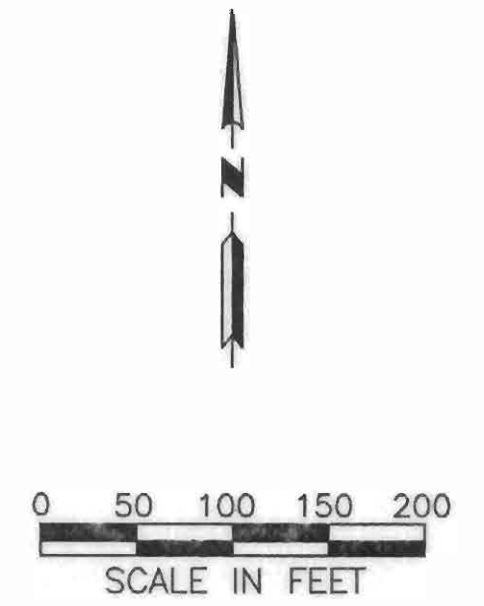

BASIS OF THE BEARING SYSTEM:
Bearings are in relationship with the south line of the SE 1/4 Section 7-107-16.

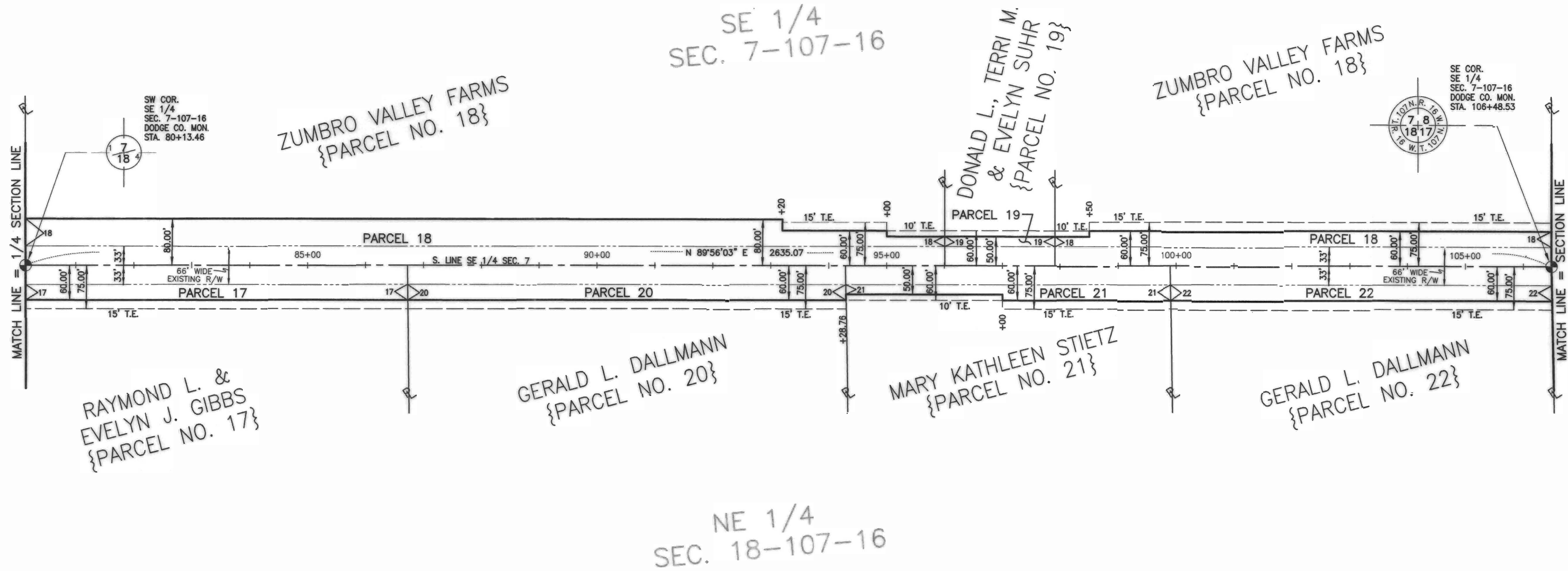









PARCEL NO.	RECORDED OWNER	LOCATION BY 1/4 SECTION	AREA OF NEW R/W (ACRES)	TEMP. EASMT (ACRES)
17	RAYMOND L. & EVELYN J. GIBBS	NE 1/4 SEC. 18-107-16	SEE SHEET 4	SEE SHEET 4
18	ZUMBRO VALLEY FARMS	SE 1/4 SEC. 7-107-16	2.08	0.37
19	DONALD L., TERRI M. & EVELYN SUHR	SE 1/4 SEC. 7-107-16	0.07	0.04
20	GERALD L. DALLMANN	NE 1/4 SEC. 18-107-16	0.47	0.26
21	MARY KATHLEEN STIETZ	NE 1/4 SEC. 18-107-16	0.29	0.16
22	GERALD L. DALLMANN	NE 1/4 SEC. 18-107-16	0.41	0.23

C 13-19

DODGE COUNTY RIGHT OF WAY PLAT NO. 20

COUNTY STATE AID HIGHWAY NO. 16

S.A.P. NO. 20-616-10

-  DODGE COUNTY MONUMENT
-  FOUND MONUMENT
-  EXISTING ROAD R/W LINES
-  NEW R/W LINES
-  EXISTING CENTERLINE
-  TEMPORARY EASEMENT LINE
-  PROPERTY LINE {PL}
-  SECTION LINE
-  QUARTER LINE

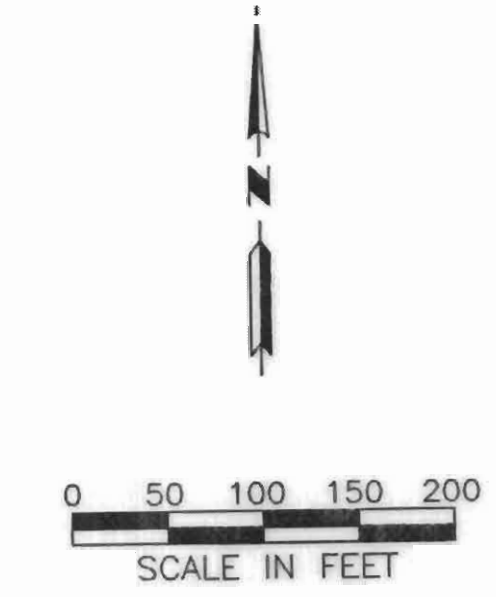

BASIS OF THE BEARING SYSTEM:
Bearings are in relationship with the south line of the SW 1/4 Section 8-107-16.

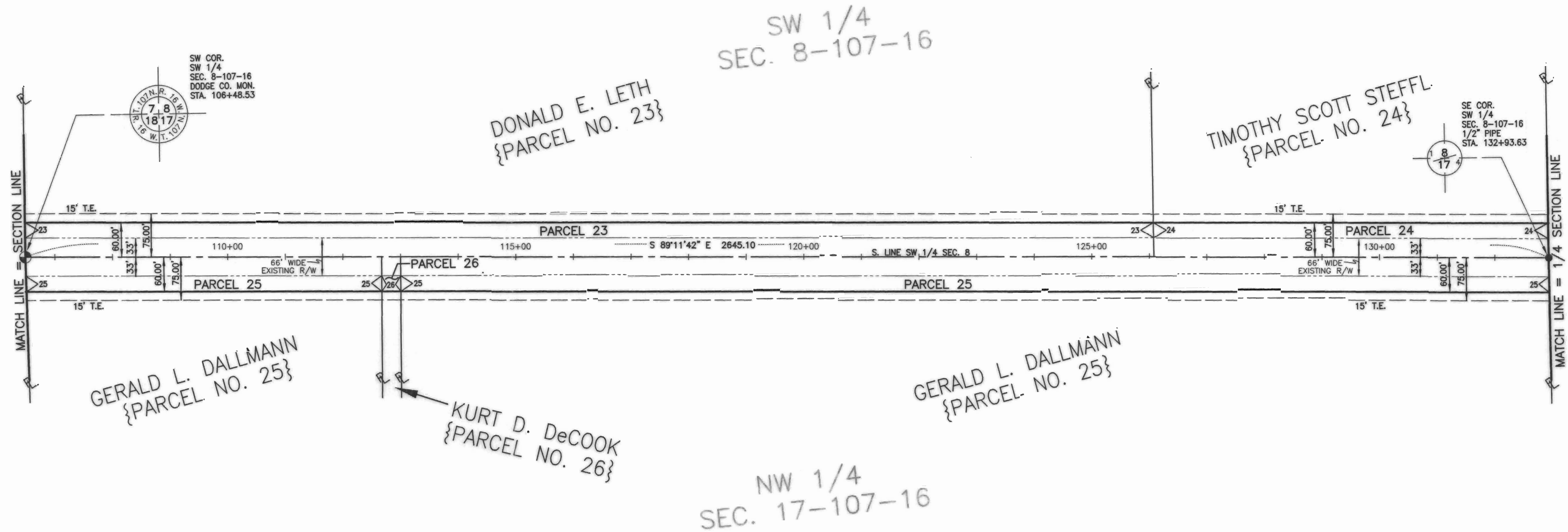

GERALD L. DALLMANN
{PARCEL NO. 25}

KURT D. DeCOOK
{PARCEL NO. 26}

GERALD L. DALLMANN
{PARCEL NO. 25}

NW 1/4
SEC. 17-107-16

C 13-20









PARCEL NO.	RECORDED OWNER	LOCATION BY 1/4 SECTION	AREA OF NEW R/W (ACRES)	TEMP. EASMT (ACRES)
23	DONALD E. LETH	SW 1/4 SEC. 8-107-16	1.21	0.67
24	TIMOTHY SCOTT STEFFL	SW 1/4 SEC. 8-107-16	0.43	0.24
25	GERALD L. DALLMANN	NW 1/4 SEC. 17-107-16	1.62	0.90
26	KURT D. DeCOOK	NW 1/4 SEC. 17-107-16	0.02	0.01

DATE: 11/27/02

DODGE COUNTY RIGHT OF WAY PLAT NO. 20

COUNTY STATE AID HIGHWAY NO. 16

S.A.P. NO. 20-616-10

-  DODGE COUNTY MONUMENT
-  FOUND MONUMENT
-  EXISTING ROAD R/W LINES
-  NEW R/W LINES
-  EXISTING CENTERLINE
-  TEMPORARY EASEMENT LINE
-  PROPERTY LINE {PL}
-  SECTION LINE
-  QUARTER LINE

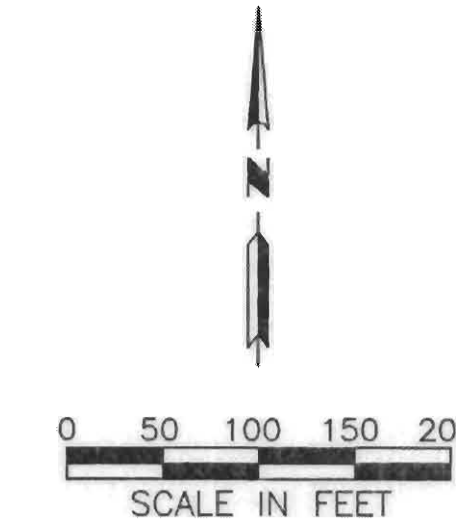

BASIS OF THE BEARING SYSTEM:
Bearings are in relationship with the south line of the SE 1/4 Section 8-107-16.

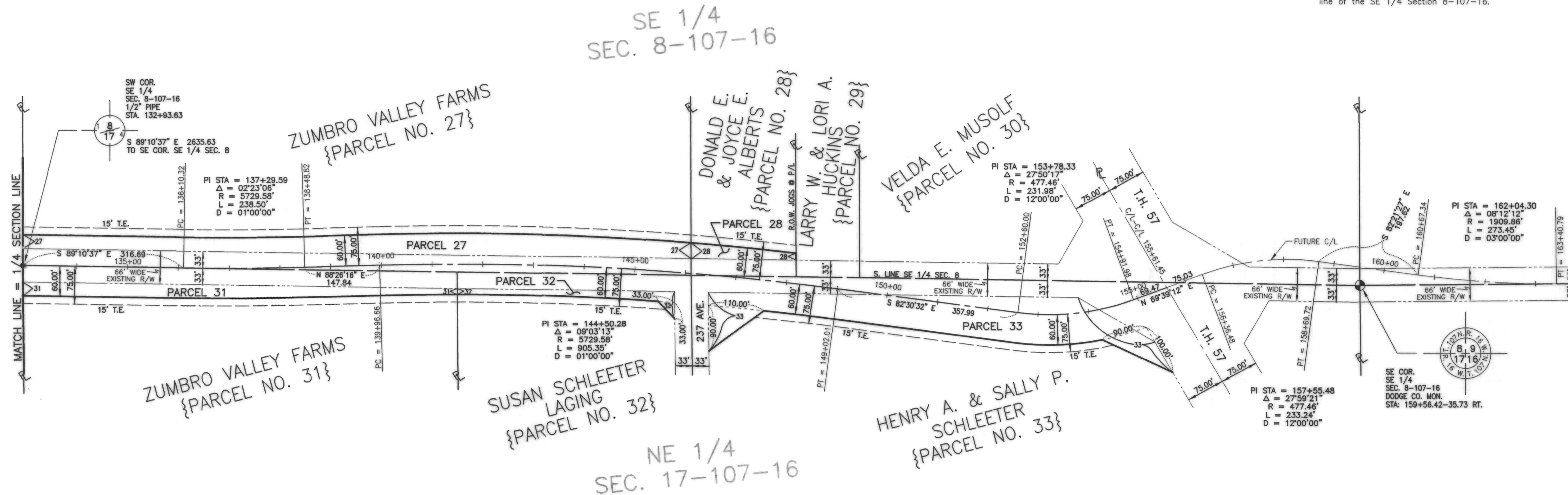

PARCEL NO.	RECORDED OWNER	LOCATION BY 1/4 SECTION	AREA OF NEW R/W (ACRES)	TEMP. EASMT (ACRES)
27	ZUMBRO VALLEY FARMS	SE 1/4 SEC. 8-107-16	1.04	0.45
28	DONALD E. & JOYCE E. ALBERTS	SE 1/4 SEC. 8-107-16	0.11	0.07
29	LARRY W. & LORI A. HUCKINS	SE 1/4 SEC. 8-107-16	0.00	0.00
30	VELDA E. MUSOLF	SE 1/4 SEC. 8-107-16	0.00	0.00
31	ZUMBRO VALLEY FARMS	NE 1/4 SEC. 17-107-16	0.45	0.29
32	SUSAN SCHLEETER LAGING	NE 1/4 SEC. 17-107-16	0.15	0.14
33	HENRY A. & SALLY P. SCHLEETER	NE 1/4 SEC. 17-107-16	1.38	0.24

C 13-21

DATE: 12/04/02